



BOROUGH OF NORTH WALES

300 School Street, North Wales, PA 19454
Phone: 215-699-4424 • Fax: 215-699-3991
<http://northwalesborough.org>

**COUNCIL MEETING
REMOTE ACCESS ONLY
Tuesday, September 22, 2020 – 7:00 P.M.**

Salvatore Amato
James Cherry
Sherwin Collins
Ronald S. Little, Jr.
Wendy McClure

Sally Neiderhiser
Eion O'Neill
James Sando
Mark Tarlecki
Gregory J. D'Angelo, Mayor

**Call to Order, Date and Time
Roll Call
Pledge of Allegiance**

1. Public Comment

2. Consideration: Approval of NMCRC Enforcement Procedures

**3. Consideration: Approval of Certificates of Appropriateness: 439 Beaver St.,
223 S. Main St. & 207 S. Fourth St.**

4. Consideration: Approval of 2021 Non-Uniform MMO

5. Consideration: Approval of 2021 Police MMO

6. Consideration: Letter of Support for SB 663 & HB 1504

7. Consideration: Approval of Disbursements: \$56,908.81

8. Consideration: Approval of Minutes: August 25, 2020

9. Old Business/Committee & Board Reports/Zoning Applications

10. Solicitor / Mayor / Council / Chief of Police / Manager

Adjournment

COVID-19 RESTRICTIONS:

In response to the Governor’s Stay Home Order due to the COVID-19 health pandemic, this meeting will be conducted via ZOOM. All members of Council, staff and public will participate remotely. The public may join this meeting by either telephone using the dial in number or entering the URL on an internet browser. Below you will find instructions on how to access and participate in the meeting:

- **Meeting URL:**
<https://us02web.zoom.us/j/84519342876?pwd=ZFJZaS9JMUVCTVJsdXo0L3FxeUJMUT09>
- **Meeting via Zoom App:** if you have the Zoom App on your smartphone, tablet, or computer, open the program, click join a meeting, and enter the Meeting ID: 845 1934 2876
- **Meeting dial in number (no video):** 1-929-205-6099
- **Meeting ID number:** (to be entered when prompted): 845 1934 2876
- **Meeting Password:** 470018

All interested parties may participate through the Zoom Conference link on the date and time noted above and when called upon by the Council President. The public may also submit questions or comments prior to the meeting by e-mail to chart@northwalesborough.org; these must be received no later than 12 Noon on September 22, 2020. Persons with disabilities who wish to attend the meeting and require auxiliary aid, service, or other accommodation to participate in the meeting should contact North Wales Borough at 215-699-4424 or by e-mail to chart@northwalesborough.org.

Mayor’s Office Hours:

2nd & 4th Tuesdays 2:00 - 4:00 PM
2nd & 4th Wednesdays 7:00 - 8:30 PM

Monthly Meeting Information:

Boards and Commissions

HARB	3 rd Wednesday of Month
Historic Commission	3 rd Tuesday of Month
Nor-Gwyn Pool Commission	2 nd Thursday of Month – 7:30 PM
Park & Recreation Board	2 nd Thursday of Month
Planning Commission	1 st Wednesday of Month
Shade Tree Commission	2 nd Thursday of Month
Zoning Hearing Board	1 st Tuesday of Month, as Needed

All above meetings begin at 7 P.M. in the Municipal Building, unless noted otherwise.

North Wales Water Authority	2 nd & 4 th Wednesday of Month 5:00 PM, 200 W. Walnut Street
------------------------------------	---

Please note: The meeting is being digitally recorded.



Regulation re: Violations of Act 101

Procedures for Act 101 Violations

1. First Offense – Upon receipt of sufficient credible evidence, a written violation warning letter may be sent to the violator (i.e., the waste hauler or municipal resident) by the NMCRC Solicitor, at the discretion of the NMCRC Solicitor, who may seek guidance from the Commission before moving forward with a written violation warning letter. A warning letter will include a statement that both the municipality and the NMCRC have enforcement powers for a violation of Act 101.
 - a. Written notice should be sent by certified mail, return receipt requested.
 - b. A copy of the written notice should be sent to the member municipality in which the violation occurred and to the NMCRC Chairman, for distribution to all member municipalities.
 - c. Written notice should include a description of each violation, identification of the section(s) of Act 101 being violated, a description of the documentation received by the member municipality evidencing the violation(s), and copies of all documentation in the member municipality's possession.
 - d. If the NMCRC Solicitor declines to issue a violation warning letter, the NMCRC Solicitor shall notify the member municipality of the decision. The member municipality may move forward with a violation warning letter.

2. Second Offense – Upon receipt of sufficient credible evidence of a second offense by the same violator within two (2) years of the date of the first offense, the municipality in which the violation occurred should notify its solicitor or code official to consider commencement of enforcement action. The municipality shall notify the NMCRC Solicitor and advise the NMCRC Solicitor whether the affected municipality intends to undertake formal enforcement action on behalf of the affected municipality. In most cases, the affected municipality will be responsible to undertake the formal enforcement action pursuant to guidelines below as set forth at length in the municipality's ordinance:
 - a. The municipality may commence a criminal action for a summary offense in Magisterial District Justice Court.
 - b. If the offense involves a commingling violation, the relief requested is likely to consist of a criminal fine not to exceed \$2,500 per violation, plus damages, court costs and reasonable attorneys' fees.
 - c. If the offense involves a violation other than commingling, the relief requested is likely to consist of a criminal fine not to exceed \$1,000 per violation, plus damages, court costs and reasonable attorneys' fees.

- d. If the offense involves a hauler knowingly collecting commingled waste from a resident previously notified of a commingling violation, the second offense upon conviction should result in a criminal fine of not less than \$1,000 and not more than \$5,000.
 - e. Each day a violation occurs is considered a separate violation for enforcement purposes.
 - f. The municipality should provide written notice of its enforcement efforts to the NMCRC Solicitor and the NMCRC Chairman, for distribution to all member municipalities.
3. Report to PADEP. If a second offense occurs and the affected municipality elects not to undertake formal enforcement action, the NMCRC Solicitor may report the occurrence of the violation to the Pennsylvania Department of Environmental Protection (“PADEP”) and request that PADEP perform an inspection of the facility or hauler that is in violation of Act 101 and, upon a determination that a violation has occurred, take appropriate enforcement action such as, but not limited to, assessing penalties and/or instituting proceedings as authorized by Act 101.
 4. Enforcement Action by NMCRC. If the violation impacts more than one NMCRC member municipality and PADEP decides not to perform an inspection and/or exercise its enforcement powers under Act 101, the NMCRC Solicitor may, after a vote by the Commission, take formal enforcement action on behalf of the affected municipalities, provided the affected municipalities enter into a cost-sharing agreement, prepared by the NMCRC Solicitor and satisfactory in form and substance to the NMCRC, relating to all costs and expenses, including attorneys’ fees, relating to the enforcement action.

Recommended Documentation Evidencing Violations

If a resident observes an alleged waste disposal or recycling violation, the resident should contact the Municipal Manager to report the alleged violation. The Municipal Manager should obtain as many factual details as possible from the resident and determine whether the resident can provide any written or visual documentation to support the alleged violation. Recommended documentation would include the following:

- Written witness statement(s) describing what activities occurred, when and where they occurred, and the identity of all witnesses and other individuals who were involved. Include the name, address and contact information for each witness who observed the violation occurrence.
- Photographs/videos taken by witnesses, including the name, address and contact information for the individual(s) who created the photograph/video.

- Certification statement signed and dated by each witness certifying that the evidence provided is correct and complete. (For example: “I, _____, hereby certify that the foregoing information provided by me is correct and complete.”)

Sample Ordinance Violations

Some common waste disposal/recycling violations include the following:

- Commingling recyclable materials with municipal solid waste
- Commingling household hazardous waste with municipal solid waste
- Commingling leaf waste with municipal solid waste
- Outdoor burning (including leaf burning)
- Collecting waste/recyclables between the hours of 8:00 pm and 6:00 am
- Violating other time, place and manner restrictions applicable to waste/recycling disposal

Municipal Websites

Each member municipality should include information on its website for reporting Act 101 violations.

THE NORTHERN MONTGOMERY COUNTY RECYCLING COMMISSION

MONTGOMERY COUNTY, PENNSYLVANIA

RESOLUTION 2020-__

A RESOLUTION ADOPTING PROCEDURES FOR THE HANDLING OF RECYCLING AND SOLID WASTE DISPOSAL VIOLATIONS BY HAULERS, BUSINESSES OR RESIDENTS OF MEMBER MUNICIPALITIES OF THE NORTHERN MONTGOMERY COUNTY RECYCLING COMMISSION.

WHEREAS, the Northern Montgomery County Recycling Commission (the “Commission”) is comprised of eleven (11) municipalities located in Montgomery County, Pennsylvania organized for the purpose of implementing the Municipal Waste Planning, Recycling and Waste Reduction Act of 1988, as amended (“Act 101”); and

WHEREAS, the member municipalities of the Commission have assigned and delegated their powers under Act 101 to the Commission in accordance with an Amended and Restated Intermunicipal Agreement dated May 21, 2007, as amended (the “Agreement”); and

WHEREAS, Section 403 of the Agreement grants to each member municipality concurrent jurisdiction with the Commission for the monitoring and enforcement of Act 101; and

WHEREAS, Section 4 of the Municipal Waste Collection and Recycling Ordinance adopted by each of the member municipalities authorizes the Commission to establish, by resolution, rules and regulations related to the administration of the recycling program and to administer and enforce against violations of all such rules and regulations; and

WHEREAS, each member municipality has delegated to the Commission pursuant to Section 8.B(2)(c) the authority to promulgate rules and regulations and to enforce those rules and regulations or to delegate such enforcement to the member municipalities; and

WHEREAS, the Commission desires to establish formal procedures for the enforcement of Act 101 and enforcement against violations by haulers, businesses and residents of its member municipalities;

NOW, THEREFORE, IT SHALL BE RESOLVED AS FOLLOWS:

Section 1. The Commission hereby adopts the enforcement procedures attached hereto as Schedule “A” and incorporated herein by this reference with the same effect as if they had been set out verbatim in this section, and a copy of which shall be filed with the minutes of the meeting at which this Resolution was adopted.

Section 2. This Resolution shall become effective at the earliest date permitted by law.

DULY ADOPTED this ____ day of _____, 2020 by the Commissioners of the Northern Montgomery County Recycling Commission, Montgomery County, Pennsylvania.

**THE NORTHERN MONTGOMERY
COUNTY RECYCLING
COMMISSION**

Attest: _____
Richard Roller, Secretary

By: _____
Richard Halbom, Chairman

Regulation re: Violations of Act 101

Procedures for Act 101 Violations

1. First Offense – Upon receipt of sufficient credible evidence and after consultation with the municipality in which the violation occurred, a written violation warning letter may be sent to the violator (i.e., the waste hauler, business or municipal resident) by the NMCRC Solicitor, at the discretion of the NMCRC Solicitor, who may seek guidance from the Commission before moving forward with a written violation warning letter. A warning letter will include a statement that both the municipality and the NMCRC have enforcement powers for a violation of Act 101.
 - a. Written notice should be sent by certified mail, return receipt requested.
 - b. A copy of the written notice should be sent to the member municipality in which the violation occurred and to the NMCRC Chairman, for distribution to all member municipalities.
 - c. Written notice should include a description of each violation, identification of the section(s) of Act 101 being violated, a description of the documentation received by the member municipality evidencing the violation(s), and copies of all documentation in the member municipality's possession.
 - d. If the NMCRC Solicitor declines to issue a violation warning letter, the NMCRC Solicitor shall notify the member municipality of the decision. The member municipality may move forward with a violation warning letter.

2. Second Offense – Upon receipt of sufficient credible evidence of a second offense by the same violator within two (2) years of the date of the first offense, the municipality in which the violation occurred should notify its solicitor or code official to consider commencement of enforcement action. The municipality shall notify the NMCRC Solicitor and advise the NMCRC Solicitor whether the affected municipality intends to undertake formal enforcement action on behalf of the affected municipality. In most cases, the affected municipality will be responsible to undertake the formal enforcement action pursuant to guidelines below as set forth at length in the municipality's ordinance:
 - a. The municipality may commence a criminal action for a summary offense in Magisterial District Justice Court.
 - b. If the offense involves a commingling violation, the relief requested is likely to consist of a criminal fine not to exceed \$2,500 per violation, plus damages, court costs and reasonable attorneys' fees.
 - c. If the offense involves a violation other than commingling, the relief requested is likely to consist of a criminal fine not to exceed \$1,000 per violation, plus damages, court costs and reasonable attorneys' fees.

- d. If the offense involves a hauler knowingly collecting commingled waste from a resident or business previously notified of a commingling violation, the second offense upon conviction should result in a criminal fine of not less than \$1,000 and not more than \$5,000.
 - e. Each day a violation occurs is considered a separate violation for enforcement purposes.
 - f. The municipality should provide written notice of its enforcement efforts to the NMCRC Solicitor and the NMCRC Chairman, for distribution to all member municipalities.
3. Report to PADEP. If a second offense occurs and the affected municipality elects not to undertake formal enforcement action, the NMCRC Solicitor may report the occurrence of the violation to the Pennsylvania Department of Environmental Protection (“PADEP”) and request that PADEP perform an inspection of the facility or hauler that is in violation of Act 101 and, upon a determination that a violation has occurred, take appropriate enforcement action such as, but not limited to, assessing penalties and/or instituting proceedings as authorized by Act 101.
4. Enforcement Action by NMCRC. If the violation impacts more than one NMCRC member municipality and PADEP decides not to perform an inspection and/or exercise its enforcement powers under Act 101, the NMCRC Solicitor may, after a vote by the Commission, take formal enforcement action on behalf of the affected municipalities, provided the affected municipalities enter into a cost-sharing agreement, prepared by the NMCRC Solicitor and satisfactory in form and substance to the NMCRC, relating to all costs and expenses, including attorneys’ fees, relating to the enforcement action.

Recommended Documentation Evidencing Violations

If a resident or business observes an alleged waste disposal or recycling violation, the resident should contact the Municipal Manager to report the alleged violation. The Municipal Manager should obtain as many factual details as possible from the resident or business and determine whether the resident or business can provide any written or visual documentation to support the alleged violation. Recommended documentation would include the following:

- Written witness statement(s) describing what activities occurred, when and where they occurred, and the identity of all witnesses and other individuals who were involved. Include the name, address and contact information for each witness who observed the violation occurrence.
- Photographs/videos taken by witnesses, including the name, address and contact information for the individual(s) who created the photograph/video.

- Certification statement signed and dated by each witness certifying that the evidence provided is correct and complete. (For example: “I, _____, hereby certify that the foregoing information provided by me is correct and complete.”)

Sample Ordinance Violations

Some common waste disposal/recycling violations include the following:

- Commingling recyclable materials with municipal solid waste
- Commingling household hazardous waste with municipal solid waste
- Commingling leaf waste with municipal solid waste
- Outdoor burning (including leaf burning)
- Collecting waste/recyclables between the hours of 8:00 pm and 6:00 am
- Violating other time, place and manner restrictions applicable to waste/recycling disposal

Municipal Websites

Each member municipality should include information on its website for reporting Act 101 violations.

Historical Architectural Review Board

Record of Action

Date 9.18.2020

Application: 0920-02

Application date: 9.10.2020

Applicant/Property Owner: Miles Moser
612 E. Montgomery Ave.
North Wales, PA 19454

Proposed Property Rehab.
439 Beaver St.
North Wales, PA 19454

Block/Unit # 14-008/015

Submittals: Application, construction drawings and photographs.

• • •

HARB Meeting: September 16, 2020 (online via Zoom)

In attendance: Mr. Joseph Del Ciotto
Mr. Charles Guttenplan
Rev. Amy Smith
Mr. James Schiele
Mr. Ray Tschoepe

Applicant in Attendance: Mr. Miles Moser

Action: **Approve with qualifications.**

Qualification(s):

1. The floor will be a wood T&G floor to match the original.
2. Repair the column if possible. If unrepairable, replace only if a match can be located or manufactured.
3. Railing will be re-built in a traditional manner if an existing one is located nearby to copy. If not, a traditional railing with balusters are placed with a spacing of 1.5 to 2 times the width of the baluster will be used. The top and bottom rails should both be designed to shed water.
4. Lattice (particularly in ground contact) can be replaced in synthetic or composite material.

Findings of fact:

1. The Sec. of the Interior guidelines recommends “Repairing entrances and porches by reinforcing the historic materials. Repair will also generally include the limited replacement in kind – or with compatible substitute material –of those extensively deteriorated or missing parts of repeated features where there are surviving prototypes such as balustrades, cornices, entablatures, columns sidelights, and stairs.

Recommendation to Council: Issue Certificate of Appropriateness

Respectfully submitted,

Ray Tschoepe

HARB Chairman/Vice-chairman

Deck Damage Details – Support for Repair Building Permit

439 Beaver Street, North Wales PA 19454

Lower Lattice Work Destroyed (Ground Level) and Sinking/Settling of Roof (Right Side)



Rotted Top Decking Slats

recommend elevation by a quarter price



Column Post Rotted and Not Supported because of Deteriorating Structure Below



(NOT Pictured) Rotting Header and 2 Rotted Joists below Decking.

- ① Add additional Concrete Pier(s)
 - ④ Replace Decking (All)
 - ⑤ Replace Railing
 - ⑥ Reinforce Column
- 439 Beaver Street (Aerial View) Front Porch (All Repairs to replicate existing design)
- ② Replace Header
 - ③ Replace 2 of 5 Joists

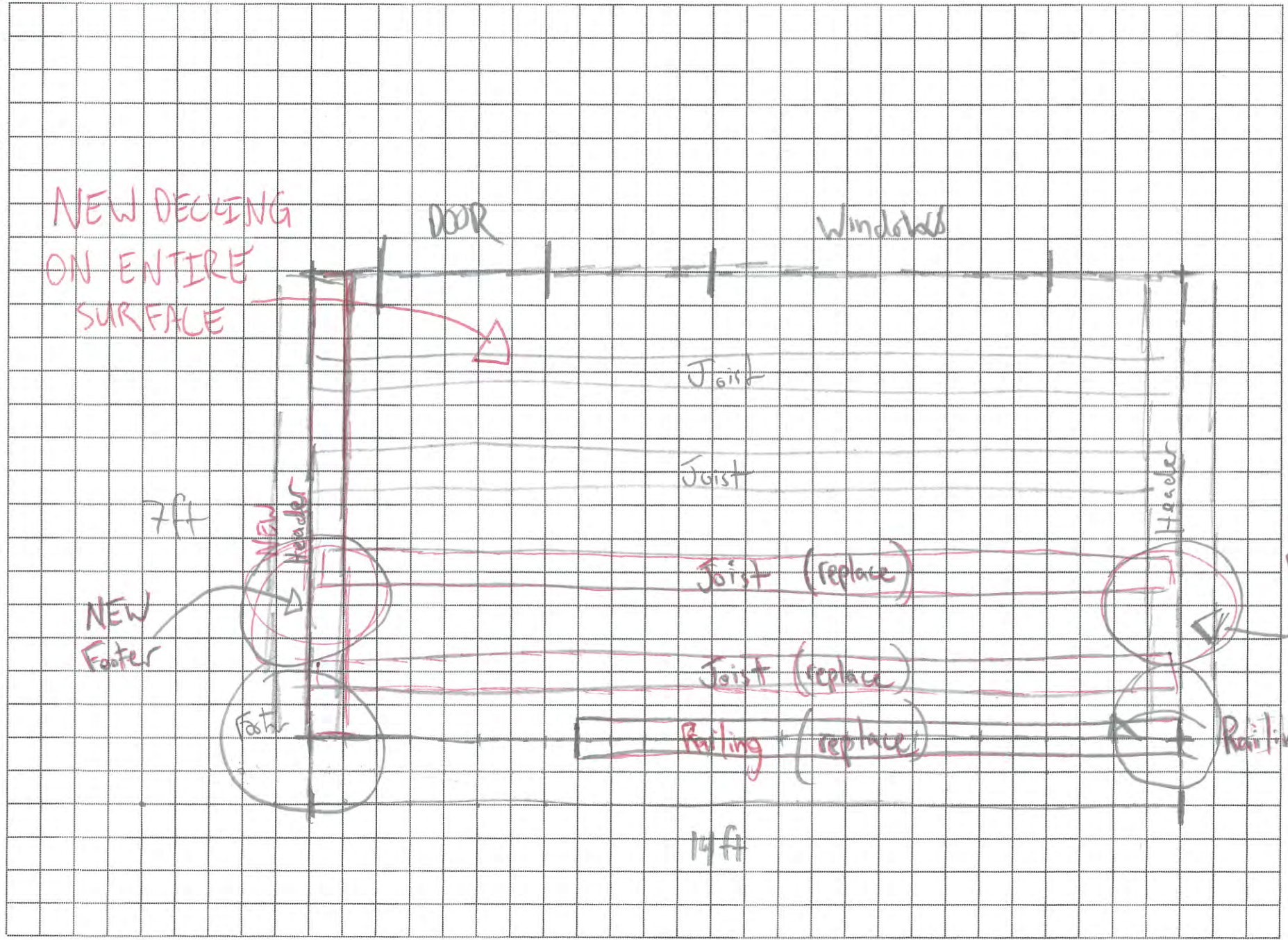

Historical Architectural Review Board

Record of Action

Date 9.18.2020

Application: 0920-03

Application date: 9.14.2020

Applicant/Property Owner: Ms. Greta Martin Washington
223 S. Main St.
North Wales, PA 19454

Block/Unit # 14-010/056

Request: Replace the failing tar over metal porch roof with another membrane roof either metal or rubber (EPDM).

Submittals: Application, construction drawings and photographs.

• • •

HARB Meeting: September 16, 2020 (online via Zoom)

In attendance: Mr. Joseph Del Ciotto
Mr. Charles Guttenplan
Rev. Amy Smith
Mr. James Schiele
Mr. Ray Tschoepe

Applicant in Attendance: Ms. Greta Martin Washington

Action: *Approve as presented.*

Findings of fact:

1. The Sec. of the Interior Guidelines for Rehab. Recommend “Replacing in kind an entire feature of the roof that is too deteriorated to repair – if the overall form and detailing are still evident – using the physical evidence to guide the new work. ... If using the same kind of material is not technically or economically feasible, then a compatible substitute material may be considered.”

Recommendation to Council: Issue Certificate of Appropriateness

Respectfully submitted,

[Ray Tschoepe](#)

HARB Chairman/Vice-chairman

Alan R. Guzzardo

From: Greta Martin Washington <greta1212@yahoo.com>
Sent: Monday, September 14, 2020 9:36 PM
To: Alan Guzzardo
Subject: Porch beam wrap detail old and new under corner post
Attachments: IMG_2160.JPG; Untitled attachment 00015.txt; IMG_2305.JPG; Untitled attachment 00018.txt

Old porch beam wrap - see the bead milled into the 5/4" white oak boards Also Note missing trim (removed when the aluminum capping was installed (A previous owner). Notice also where the fancy decorative trim was removed it's shown to have been attached to bare wood which indicates it was original to the porch.

Replacement wrap: 5/4" azak with milled bead to replicate thickness and look. A piece of molding was replaced. Current molding likely a bit more detail in the replacement molding than the original molding. Porch post is not reinstalled yet in the photo.



TP NO. 2
ALR 80857
F



Alan R. Guzzardo

From: Greta Martin Washington <greta1212@yahoo.com>
Sent: Monday, September 14, 2020 10:01 PM
To: Alan Guzzardo
Subject: Posts and fancy trim
Attachments: IMG_2310.JPG; Untitled attachment 00024.txt; IMG_2311.JPG; Untitled attachment 00027.txt

Original Posts are 5/4" white oak. They are hollow. Caps were 6/4", variety of materials, many thought to be fir. Appears they all were replaced at various times. Fancy trim is also 5/4" white oak. OG is the thick old style That is no longer standard stock. Base trim was a single wrap with no trim - likely not original.

Caps will be rebuilt with New 5/4" white oak. OG: I had a knife cut years ago from Doylestown lumber. OG That is reusable will be cleaned up. Balance will come from my stock Cut from the custom knife. Wood type was chosen for interior use. One post will be rebuilt exactly like the other three using 9 ft long, 5/4" white oak Board with pressure treated blocking at the base. The base trim around the posts will likely be azak with additional trim added. This will be done last. Details not ironed out yet.

Fancy trim will be cleaned, sealed and reinstalled. White oak from the damaged post will be used to repair the fancy trim.





Alan R. Guzzardo

From: Greta Martin Washington <greta1212@yahoo.com>
Sent: Monday, September 14, 2020 10:05 PM
To: Alan Guzzardo
Subject: Photo of side porch
Attachments: IMG_2309.JPG; Untitled attachment 00033.txt

Photo of side porch showing assembly of the upper post. Only thing I'm still looking for for the front porch is that fat round trim between the beam wrap and the ceiling boards. I have cleaned off a sample to take to Rittenhouse to see if they can cut me this profile.



Alan R. Guzzardo

From: Greta Martin Washington <greta1212@yahoo.com>
Sent: Monday, September 14, 2020 10:07 PM
To: Alan Guzzardo
Subject: The damaged post
Attachments: IMG_2153.JPG; Untitled attachment 00039.txt

You can see old repair cuts to this post. Upper portion is the white oak. Lower portion is various. We decided to build a new post rather than attempt repair again.



Alan R. Guzzardo

From: Greta Martin Washington <greta1212@yahoo.com>
Sent: Monday, September 14, 2020 10:12 PM
To: Alan Guzzardo
Subject: Porch details.
Attachments: 61991084166__FA544EA9-9010-4880-A9E8-1F1CD343F62E.JPG; Untitled attachment 00045.txt

This photo you can see the simple wrap at the base of the post. This wrap will likely be fabricated from azak with a bit more detail than currently shown. Not sure what it may have looked like originally. Open to suggestion. I do like how the wrap on old porch post did not touch the floor boards. I think that feels more authentic. Would like suggestions.



Alan R. Guzzardo

From: Greta Martin Washington <greta1212@yahoo.com>
Sent: Monday, September 14, 2020 10:14 PM
To: Alan Guzzardo
Subject: Original porch
Attachments: IMG_1942.JPG; Untitled attachment 00051.txt

See base of porch posts here.



Alan R. Guzzardo

From: Greta Martin Washington <greta1212@yahoo.com>
Sent: Monday, September 14, 2020 10:20 PM
To: Alan Guzzardo
Subject: Under porch framework
Attachments: IMG_2174.jpg; Untitled attachment 00057.txt

I'd like to have built a framework for under the porch to have a finished look. Was considering something like what is shown in the photo. I'm not a fan of the simple (XXXX) sheets stapled into the face board.



Alan R. Guzzardo

From: Greta Martin Washington <greta1212@yahoo.com>
Sent: Monday, September 14, 2020 10:37 PM
To: Alan Guzzardo
Subject: The roof.
Attachments: IMG_2298.JPG; Untitled attachment 00063.txt; IMG_2299.JPG; Untitled attachment 00066.txt; IMG_2300.JPG; Untitled attachment 00069.txt; IMG_2301.JPG; Untitled attachment 00072.txt; IMG_2302.JPG; Untitled attachment 00075.txt; IMG_2303.JPG; Untitled attachment 00078.txt

The roof is a rolled tin roof with a yankee gutter. Slope is fairly flat. Given that and the elevation difference of house to street, The drip edge is the only part of the roof visible from the street. It has years of pitch built up. There is one down spout on the church street side.

The center of the roof slopes to main street. The ends slope toward the sides of the house. You can see the slope best by the exposed brick.

It's too flat for shingles. Rolled tin does not seem to be a standard roofing product anymore. Quotes provided were for rubber type product.













Historical Architectural Review Board

Record of Action

Date 9.18.2020

Application: 0820-03 (revisited)

Application date: 8.05.2020

Applicant/Property Owner: Gwynedd Racquet Club
207 S. Fourth St.
North Wales, PA 19454

Block/Unit # 14-015/023

Request: Replace stained glass windows with insulated glass windows.
Construct a deck on the north side of the building.

Submittals: Application, construction drawings and photographs.

• • •

HARB Meeting: August 19, 2020 (online via Zoom)
September 16, 2020 (online via Zoom)

In attendance: Mr. Joseph Del Ciotto
Mr. Charles Guttenplan
Rev. Amy Smith
Mr. James Schiele
Mr. Ray Tschoepe

Applicant in Attendance: Mr. Robert Gundlach Jr. and Mr. William Rux

Action: *Approve with qualifications.*

Qualifications:

1. The existing stained-glass window on the first floor of the street facing façade will be repaired and retained in working order. The second/third floor window is replaced with more energy efficient moveable sash with clear glass infill between the sash from lintel to sill. All of the removed stained-glass sash is to be safely crated and stored in a dry place on site.
2. The deck is to be constructed without a physical tie into the church stucco wall. It can be tied into the stone wall of the ell, but should be braced free standing on the other three sides.

Findings of fact:

1. The Sec. of the Interior Guidelines recommend, “Designing and installing new windows, when the historic windows (frames, sash and glazing) are completely missing. The replacement windows may be an accurate restoration using , historic, pictorial, and physical documentation; or be a new design that is compatible with the window openings and the historic character of the building.”
2. The Sec. of the Interior Guidelines recommend, “Designing new exterior additions to historic buildings or adjacent new construction which is compatible with the historic character of the of the site and which preserve the historic relationship between the building or buildings, landscape features or open space.”

Recommendation to Council: Issue Certificate of Appropriateness

Respectfully submitted,

Ray Tschoepe

HARB Chairman/Vice-chairman



Stone Manor Corporate Ctr.
2700 Kelly Road Suite 300
Warrington, PA 18976
Tel (215) 345-7500 Fax (215) 345-7507
www.foxrothschild.com

ROBERT W. GUNDLACH, JR.
Direct No: 215.918.3636
Email: RGundlach@FoxRothschild.com

September 14, 2020

VIA EMAIL: chart@northwalesborough.org

Christine A. Hart
Borough Manager
North Wales Borough
300 School Street
North Wales, PA 19454

Re: Gwynedd Racquet Club – 207 S. 4th Street, North Wales, PA

Dear Christine:

Thank you for meeting with us concerning the proposal of GRC to replace windows in the front of the building and to install a deck on the side/rear of the building. Based on this meeting, we are modifying our proposal to HARB as follows:

A. As to the front windows, GRC is now proposing the following:

(1) As to the lower windows in the front of the building (which are stain glass), we will keep them as is, but clean them up from their current condition. We will remove the metal mesh and plastic coverings. We will also repair the damaged windows and give them all a cleaning. This work has already commenced.

(2) As to the upper windows in front of the building, we are proposing to keep the four windows that were recently installed. However, we will remove all wood sections (8 in total) and install clear glass windows in their place. Therefore, there will be clear glass from top to bottom in each of the four windows. The four new windows, with half circles, will be a custom order.

(3) We will repair and repaint the trim around all of the windows in the front of the building as part of this window replacement project.

B. As to the deck, GRC is now proposing the following:

September 14, 2020

Page 2

(1) We will install lattice along the underside of the front and side of the deck that can be seen from Montgomery Avenue.

(2) We will install evergreen or arborvitae trees between the front north-eastern corner of the building and the side yard so that the deck is somewhat obscured by the new trees. The trees will also provide privacy for those on the deck as and when they grow to mature width and height.

(3) The existing storage shed on the side of the building will be removed.

Attached are some additional photos of the front of the building, where the windows are proposed to be repaired and replaced, and the side of the building where the deck is proposed.

If you should have any questions, please advise. Otherwise, please confirm that we will be included back on the agenda of HARB for their meeting on Wednesday, September 16, 2020. Separately, we intend to file an application for zoning relief to install the proposed deck after we obtain a site plan showing the property boundary lines and the deck location within the rear/side yard.

Sincerely,



Robert W. Gundlach, Jr.

RWG:lm

Enclosures

cc: Lach McIntosh, President (via email)
Doug Baird, Secretary (via email)
Guenter Wesch, Treasurer (via email)
Bill Rux, Manager, Special Projects (via email)
Alan Guzzardo, Asst. Borough Manager (via email)



GWYNEDD
RACQUET CLUB

U.S. SQUASH











August 5, 2020

VIA EMAIL: chart@northwalesborough.org

Christine A. Hart
Borough Manager
North Wales Borough
300 School Street
North Wales, PA 19454

Re: Gwynedd Racquet Club – 207 S. 4th Street, North Wales, PA

Dear Christine:

As a follow up to our recent conversation, enclosed please find an application to the Borough's Historical Architectural Review Board for approval to replace the windows in the front of the above-referenced property.

By way of brief background, this property has been used as a Club/fitness center for the past 40-50 years. At same point prior to that, way before my time, I understand that it was used as a church. The windows in the front of the building were the old stained glass church windows. Not insulated. They have deteriorated over the years as some of them were broken and vandalized. Many were damaged beyond repair. The Club would like to replace them with insulated windows.

The Club is open to working with the Borough and the Historical Architectural Review Board to respect the historic architectural integrity of this portion of the building in the completion of this work. Please include this application on the agenda of the Historical Architectural Review Board for their meeting on August 19, 2020. If that is not possible, then please include us for their next meeting on September 16, 2020. We would like to schedule a meeting at the property with the Chairman and any others you deem appropriate prior to the formal meeting before the Historical Architectural Review Board to further discuss this work. We have the old windows at the Club. See attached photo.

If you should have any questions, please advise. I can be reached by email at rwgundlach@gmail.com or by cell (215) 313-8000. Thanks.

Sincerely,



Robert W. Gundlach, Jr.

RWG:lm
Enclosures

cc: Lach McIntosh, President (via email)
Doug Baird, Secretary (via email)

August 5, 2020

Page 2

Guenter Wesch, Treasurer (via email)

Bill Rux, Manager, Special Projects (via email)



SUNDAY SCHOOL

RESERVED

Alan R. Guzzardo

From: Gundlach, Robert W. <RGundlach@foxrothschild.com>
Sent: Tuesday, August 11, 2020 6:19 PM
To: Alan R. Guzzardo
Cc: Christine Hart; Coulter, Grace; imrux@verizon.net; dbaird902@icloud.com; lachlan1970@gmail.com; guenterwesch@gmail.com
Subject: Re: [EXT] RE: Gywnedd Racquet Club – 207 S. 4th Street, North Wales

This email will confirm our request to include the request for the deck permit as part of the pending HARB application. Thanks.

Robert W. Gundlach, Jr., Esquire
Partner and Co-Chair, Real Estate Department
Fox Rothschild, LLP
Office: 215-918-3636
Cell: 215-313-8000
RGundlach@foxrothschild.com
Sent from my iPhone

On Aug 11, 2020, at 1:28 PM, Alan R. Guzzardo <aguzzardo@northwalesborough.org> wrote:

Good afternoon Rob,

I just received a deck permit application from Bill. Please be advised that this also needs to be reviewed by HARB. Please amend your application to include the deck and I'll forward both the window and decks specs to the Board. Please let me know if you have any questions and/or concerns. Thank you.

Alan R. Guzzardo
Assistant Borough Manager
<image001.jpg>

From: chart@northwalesborough.org <chart@northwalesborough.org>
Sent: Wednesday, August 05, 2020 4:23 PM
To: 'Coulter, Grace' <gcoulter@foxrothschild.com>
Cc: Alan Guzzardo <aguzzardo@northwalesborough.org>
Subject: RE: Gywnedd Racquet Club – 207 S. 4th Street, North Wales

Rec'd – I have copied Mr. Guzzardo, he will notify you with the details preceding the HARB

From: Coulter, Grace <gcoulter@foxrothschild.com>
Sent: Wednesday, August 05, 2020 12:56 PM
To: chart@northwalesborough.org
Cc: Gundlach, Robert W. <RGundlach@foxrothschild.com>; imrux@verizon.net; dbaird902@icloud.com;

Bill Rux 215-284-1088

PLOT PLAN WORK SHEET

<u>INFORMATION</u>	
Property Address:	207 S. 4th St. North Wales PA
Zoning District:	C
	Plan Scale: 1" = 25'
Page 1	<u>PLOT PLAN</u>

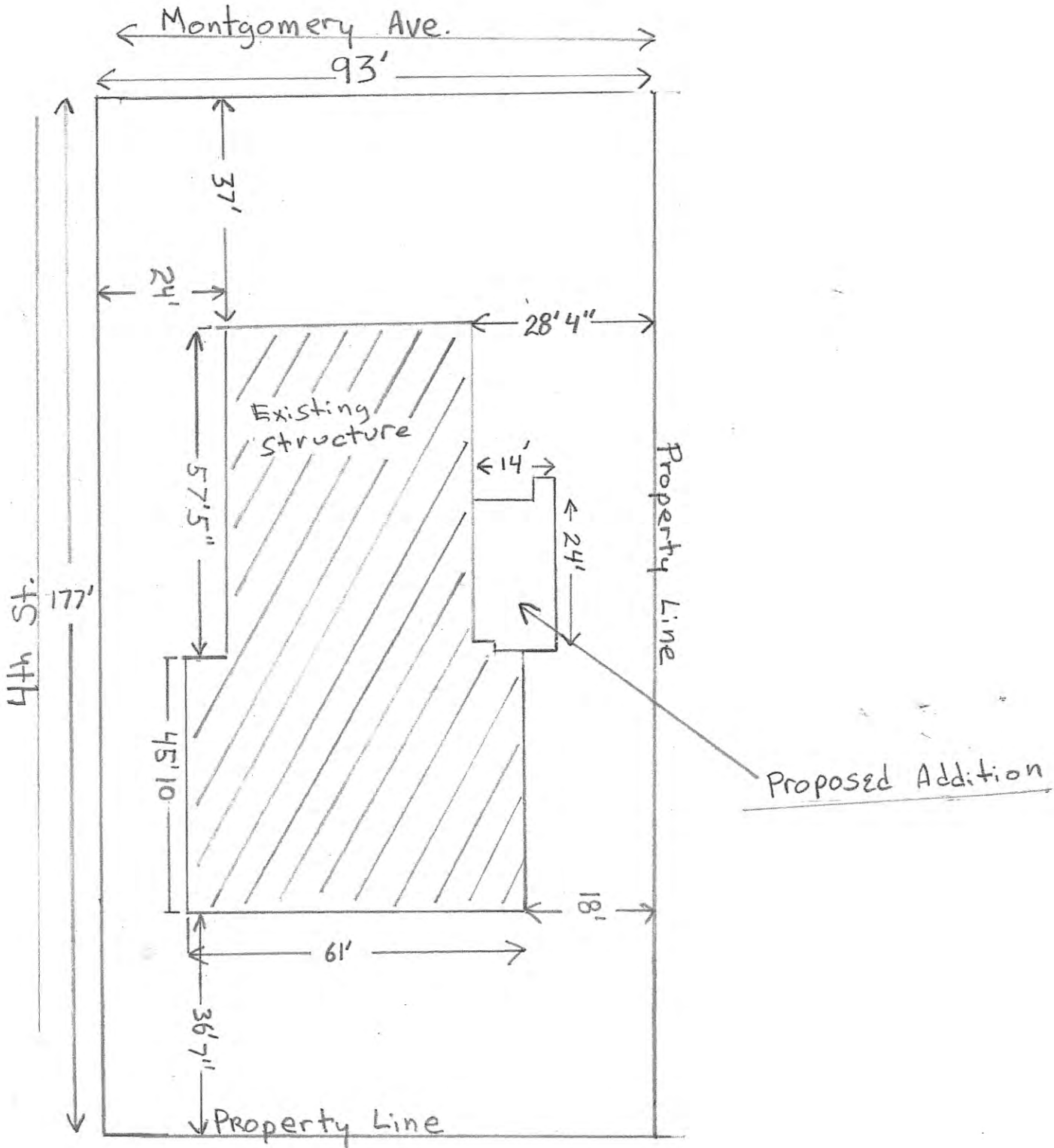

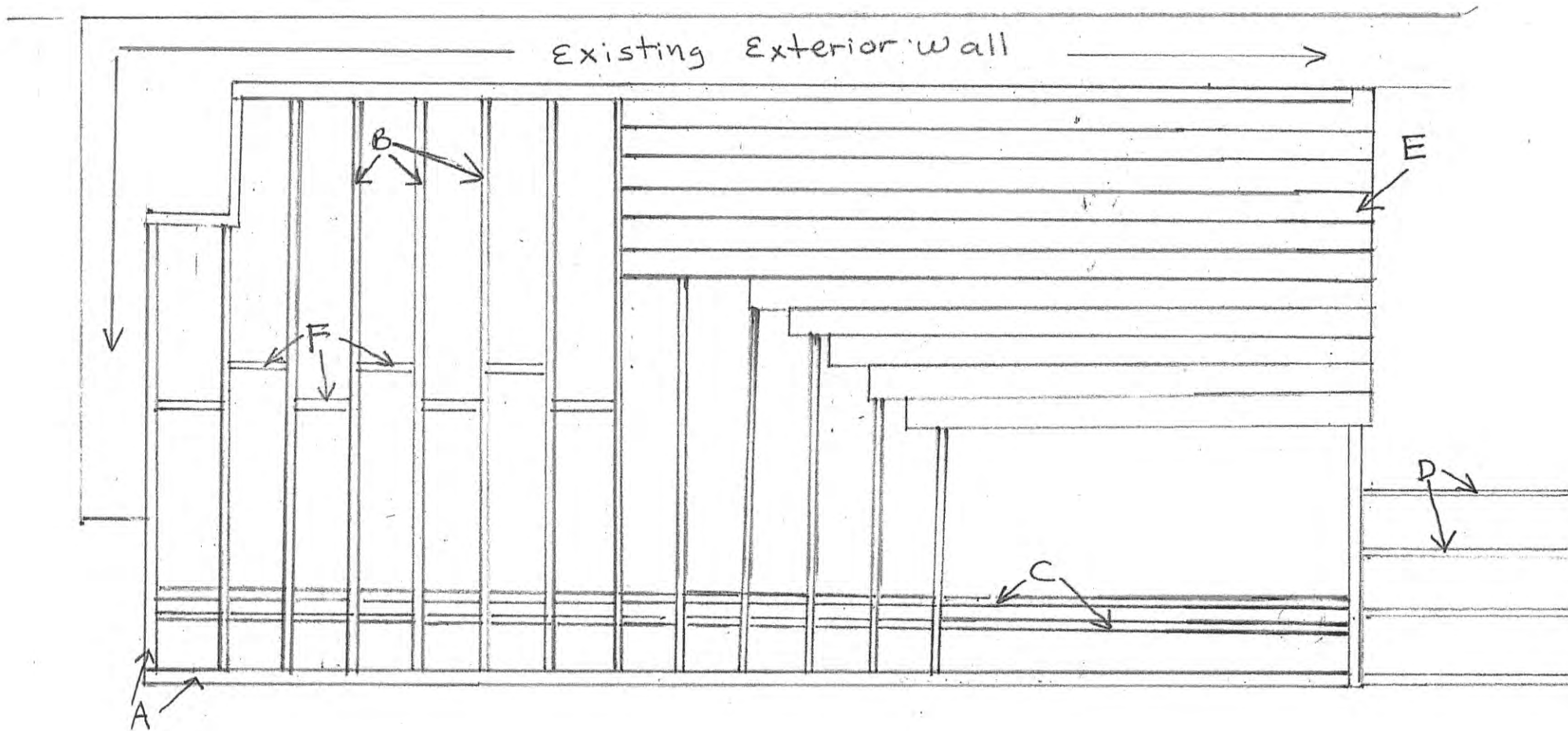

Framing detail

- A. Rim joists: Pressure treated 2 x 10 attached to existing exterior stone wall with 3/8 x 4" sleeve anchors @ 48" on center
- B. Interior (deck) joists: Pressure treated 2 x 10 attached to rim joists with 2 x 10 slant nail joist hangers
- C. Support beams: (2) Pressure treated 2 x 10 attached to floor joists with galvanized rafter ties
- D. Stairs: (4) 2 x 12 pressure treated, attached to rim joists with CHZ-TZ type stringer hangers
- E. Decking: Typical 1 x 6 composite, attached with decking screws at joists
- F. Blocking: Pressure treated 2 x 10 attached between each joist with (3) galvanized 16d common nails

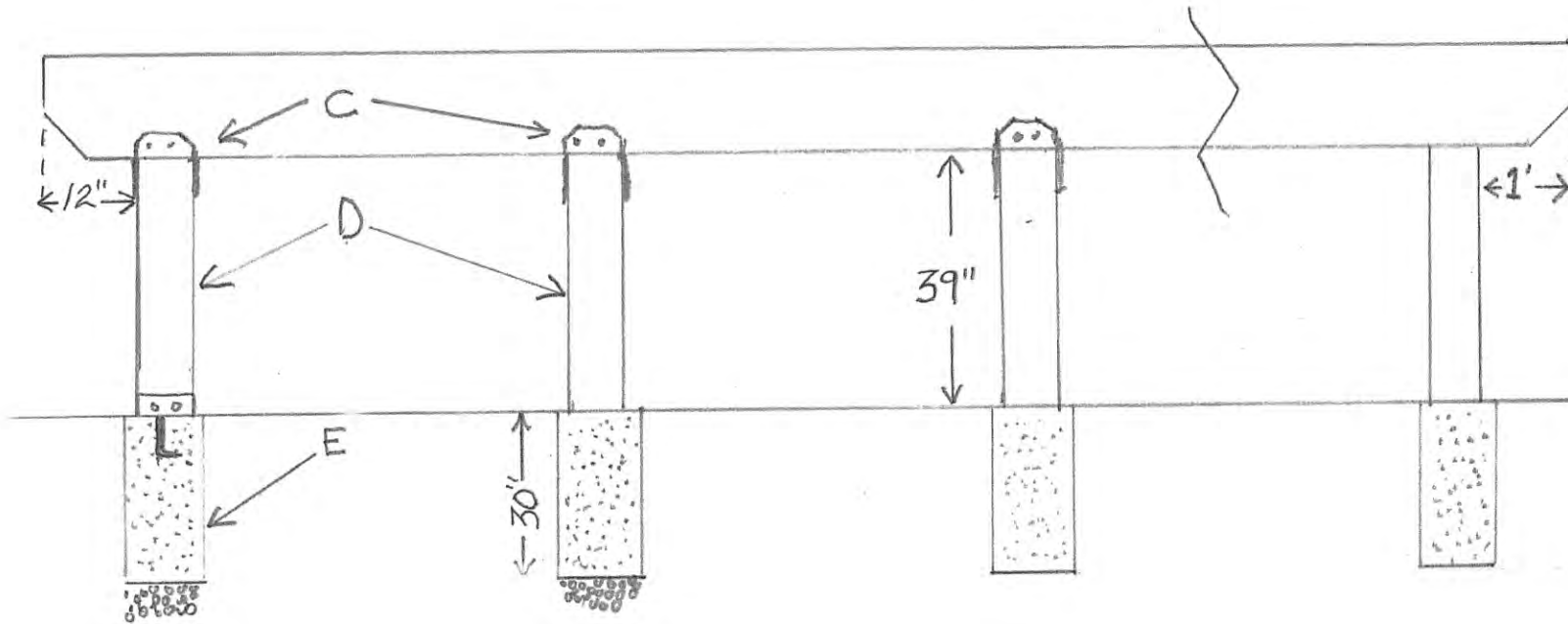
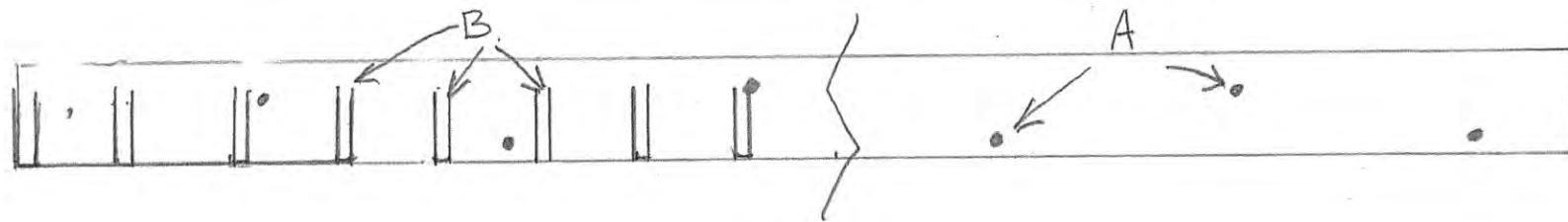

- A. 2 x 10 pressure treated lumber attached to exterior wall with 3/8" x 4" sleeve anchors
- B. 2 x 10 galvanized slant nail joist hangers spaced @ 16" on center
- C. (2) 2 x 10 beams attached to 6 x 6 posts with C44-TZ galvanized post caps, using 1 1/2" galvanized joist nails.
- D. (4) 6 x 6 pressure treated posts, spaced @ 7'3" o.c. attached to post anchors with 1/2" x 6" L-bolts embedded in footings
- E. (4) 8" diameter by 30" deep concrete footings with 3" gravel base below.

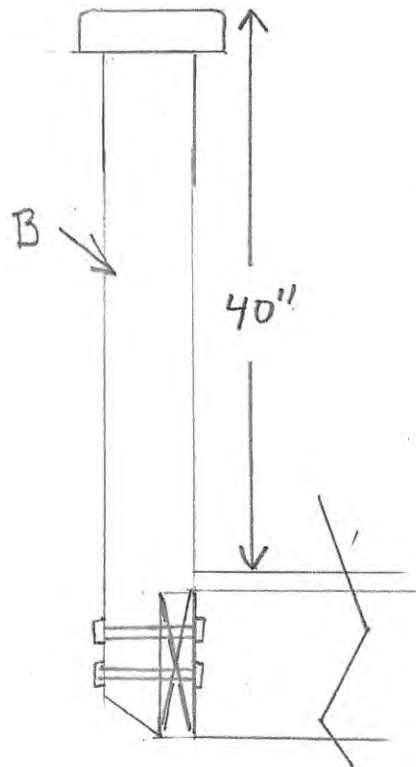
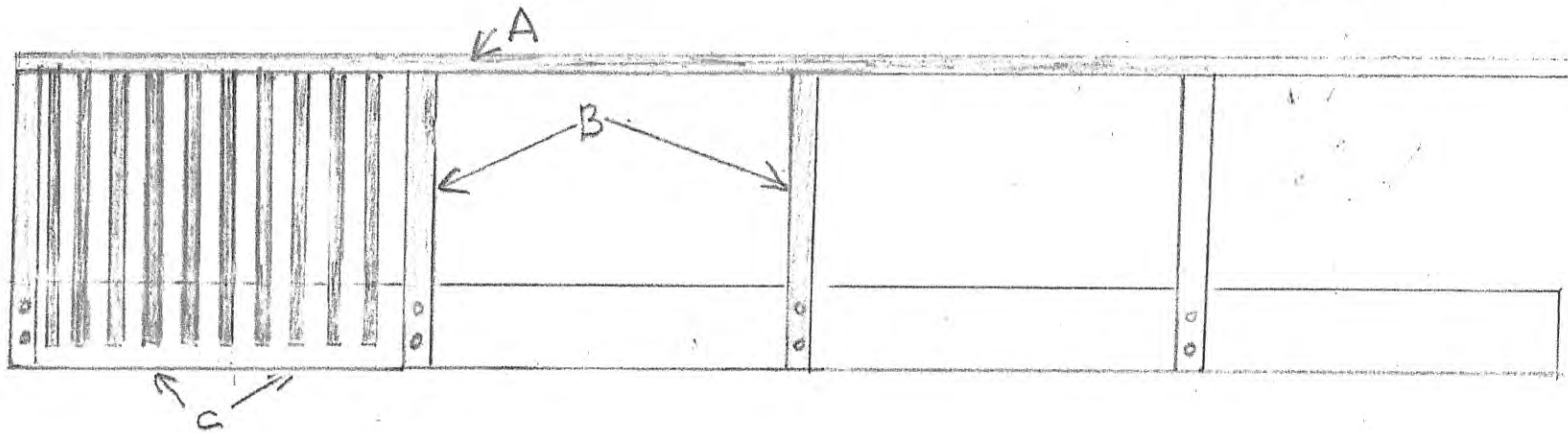

Handrail Detail

- A. Pressure treated 2x6 handrail attached to posts with deck screws
- B. Pressure treated 4 x 4 railing posts attached to ledger with zinc 3/8" x 5" carriage bolts @ (approx.) 6' on center
- C. Pressure treated 2x2 balusters attached to ledger with 3" exterior screws spaced 4 inches apart

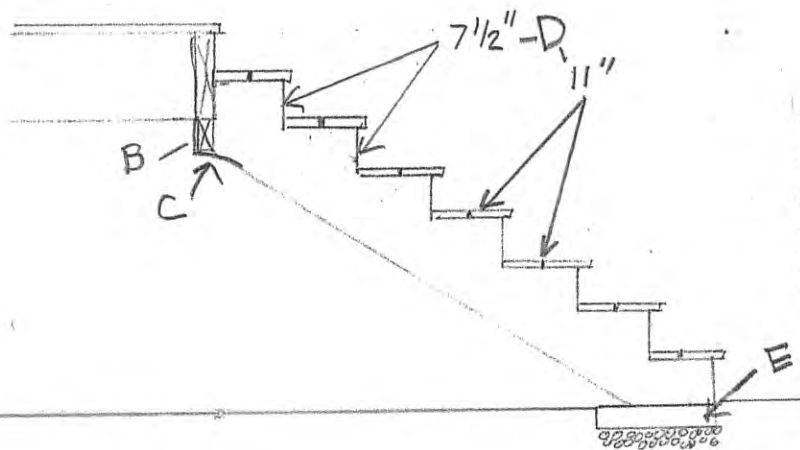
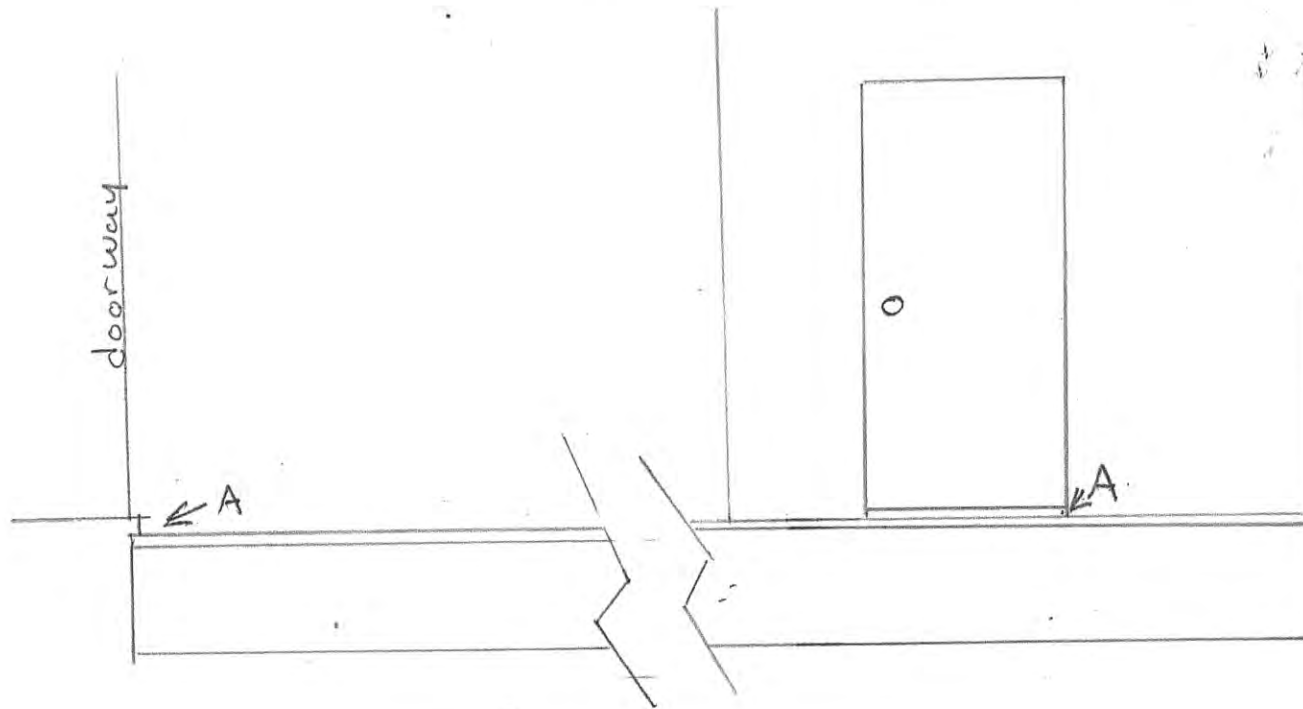

- A. Top of finished deck is 1" below bottom of existing doorway threshold
- B. 2 x 4 pressure treated blocking for stair support
- C. (4) concealed stringer hangers for support
- D. Treads 11", risers 7 1/2"
- E. 4' wide by 1' by 2 1/2" deep concrete base

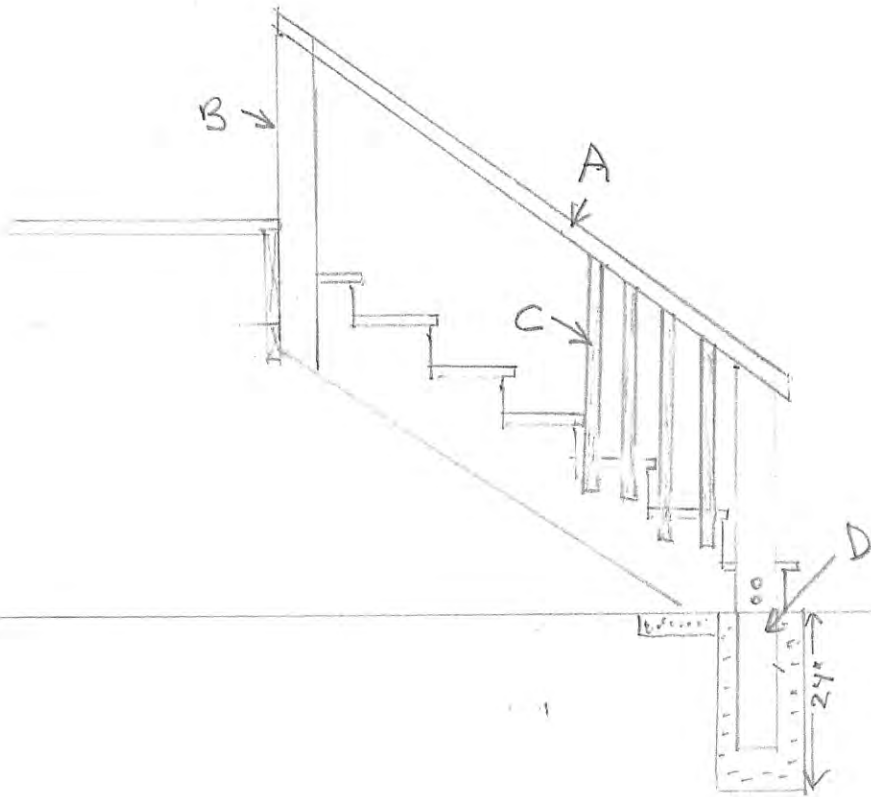

Railing detail (left and right side):

- A. pressure treated 2x6 to match elevation of deck railing
- B. 4 x 4 post attached to rim joists with 3 x 5" carriage bolts
- C. P.t. 2 x 2 balusters to match deck railing (4" spacing between)
- D. Bottom post: p.t. 4 x 4 embedded in concrete 24" deep



BOROUGH OF NORTH WALES

Memorandum

To: North Wales Borough Council

From: Christine Hart

Date: 09/22/2020

Re: The 2021 Minimum Municipal Obligation (MMO) for the North Wales Borough Non-Uniformed Pension Plan

Act 205 of 1984, as amended, governs the funding requirements for all municipal pension plans. The law requires the Chief Administrative Officer of each municipal pension plan to inform the governing board of the municipality of the Plan's expected financial obligation for the coming year. This must be done by the last business day in September.

The calculation of the 2021 Plan cost, or the MMO, required an estimate of the 2021 W-2 wages of the employees covered by the plan. I have indicated on the attached worksheet my best estimate of the same. Questions on the pension cost calculation may be addressed to either myself or the Pennsylvania Municipal Retirement System at 800-622-7968.

The MMO is the municipality's 2021 bill for this pension plan and must be paid by December 31, 2021. The obligation must be met with general fund monies or with any General State Aid to Municipal Pensions to which we may be entitled to under Act 205.

Attachment: 2021 MMO Worksheet

The Minimum Municipal Obligation Worksheet (MMO)
For the
North Wales Borough Pension Plan (46-096-3 N)

For Plan Year 2021

Estimated 2020 W-2 Payroll
For Covered Plan Members: (A) 165,000.00

Contracted Employer Contribution
Rate Expressed as a Decimal (B) .07

RESULT: (A) * (B) = (C) 11,550.00

Administrative Charge (PMRS Determined)
of Plan Members times \$20 (D) 100.00

MINIMUM MUNICIPAL OBLIGATION

Equals (C) + (D) (MMO) \$11,650.00

Prepared By: Christine A. Hart
Borough Manager

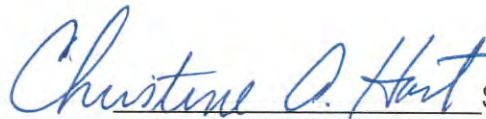
 Signature
215-699-4424 (Phone)

Plan Member Status in PMRS

North Wales Borough 46-096-3-N

Member Name	MKEY	Plan Status as of August 11, 2020
Fredericks, Geraldine M.	1077749	Retired
Guzzardo, Alan	1086909	Active
Hart, Christine A	1083547	Active
Liebel, Claire Ann	1077748	Retired
Walter, Deborah	1077747	Active

Active Members	3	Retired Members	2
Vested Members	0	Retired (Survivors):	0
		Retired (Disabled):	0

Total Membership 5
(Active/Vested/Retired)

46-096-3 N

DUDA ACTUARIAL CONSULTING



Philadelphia Office
500 Office Center Drive
Suite 400
Fort Washington, PA 19034
Phone: 267-513-1714
Fax: 484-636-2500

Pittsburgh Office
One Oxford Centre
301 Grant Street
Suite 4300
Pittsburgh, PA 15219
Phone: 412-255-3746
Fax: 412-255-3701

September 13, 2020

Ms. Christine Hart
Borough Manager
Borough of North Wales
300 School Street
North Wales, PA 19454

RE: Borough of North Wales Police Pension Plan
2021 Minimum Municipal Obligation

Dear Christine:

As requested, we have completed the calculation of the 2021 Minimum Municipal Obligation for the Borough of North Wales Police Pension Plan. This calculation was based on the January 1, 2019 Actuarial Valuation and reflects a 5% of pay police contribution. Please keep in mind that this document must be submitted to the governing body by September 30, 2020 (although revisions may be made up to the time the budget is finalized).

Should you have any questions or require any additional information, please feel free to contact us.

Sincerely Yours,

Joseph W. Duda, FSA, FCA, EA, MAAA
President

Enclosures

**FINANCIAL REQUIREMENT AND MINIMUM MUNICIPAL OBLIGATION
BUDGET FOR 2021**

NAME OF MUNICIPALITY: BOROUGH OF NORTH WALES

COUNTY: MONTGOMERY

	POLICE PENSION PLAN
1. TOTAL ANNUAL PAYROLL (Estimated W-2 Salary for 2020)	\$ 457,716
2. TOTAL NORMAL COST PERCENTAGE (Derived from latest actuarial valuation 1/1/19)	13.04%
3. TOTAL NORMAL COST (Item 1 times Item 2)	59,686
4. TOTAL AMORTIZATION REQUIREMENT (Derived from latest actuarial valuation 1/1/19)	15,597
5. TOTAL ADMINISTRATIVE EXPENSES (Based on most recent experience)	13,346
6. TOTAL FINANCIAL REQUIREMENT (Item 3 + Item 4 + Item 5)	88,629
7. TOTAL MEMBER CONTRIBUTIONS	22,886
8. FUNDING ADJUSTMENT (Derived from latest actuarial valuation 1/1/19)	0
9. MINIMUM MUNICIPAL OBLIGATION (Item 6 - Item 7 - Item 8)	\$ 65,743

*A funding adjustment exists only if the assets exceed accrued liability as reported in the latest actuarial valuation and is determined pursuant to Section 302 (C) of Act 205 of 1984.

Signature of Chief Administrative Officer

Date Certified to Governing Body

Borough of North Wales CHECK DETAIL REPORT

September 2020

0110010 - GENERAL FUND CHECKING

Date	Num	Name		
09/08/2020	6981	BOROUGH OF NORTH WALES POLICE PENSIONPL	\$	1,919.73
09/08/2020	6982	DELAWARE VALLEY HEALTH TRUST	\$	6,722.46
09/08/2020	6983	PECO 01711-30377 (EVENT ST POWER)	\$	30.49
09/08/2020	6984	PECO 23654-10011 (PW - 599 ELM)	\$	37.36
09/08/2020	6985	PECO 32937-01304 BORO HALL	\$	35.76
09/08/2020	6986	PECO 63863-01003 PW GARAGE	\$	30.39
09/08/2020	6987	PECO 63864-01609 WALNUT SQUARE	\$	33.37
09/08/2020	6988	PECO 66955-01103 PW GARAGE	\$	65.94
09/08/2020	6989	PECO 70344-01702 BORO HALL	\$	580.42
09/08/2020	6990	PECO 79323-09073 125 N MAIN	\$	51.22
09/08/2020	6991	PENNSYLVANIA MUNICIPAL RETIREMENT SYSTEM	\$	721.67
09/08/2020	6992	RICHARD HAGY	\$	120.00
09/08/2020	6993	SWIF - STATE WORKERS' INSURANCE FUND	\$	5,668.00
09/08/2020	6994	VERIZON S0007570	\$	166.37
09/08/2020	6995	VERIZON WIRELESS	\$	171.76
09/08/2020	6996	VOYAGER FLEET SYSTEMS INC.	\$	743.64
09/08/2020	6997	DCED	\$	112.50
09/22/2020	6998	21st CENTURY MEDIA - PHILLY CLUSTER	\$	1,993.53
09/22/2020	6999	AMAZON CAPITAL SERVICES, INC.	\$	182.71
09/22/2020	7000	BOUCHER & JAMES INC.	\$	21,091.45
09/22/2020	7001	BUCKS COUNTY COURT REPORTERS, LLC	\$	325.00
09/22/2020	7002	CARDMEMBER SERVICE	\$	562.09
09/22/2020	7003	DANIEL NATALE	\$	375.00
09/22/2020	7004	FISHERS ACE HARDWARE & RENTAL	\$	247.66
09/22/2020	7005	HAMBURG RUBIN MULLIN MAXWELL	\$	924.00
09/22/2020	7006	JL REYES ACCOUNTING & TAX SERVICE LLC	\$	900.00
09/22/2020	7007	KEYSTONE MUNICIPAL SERVICES, INC	\$	750.00
09/22/2020	7008	L.I.P. COLLISON, INC	\$	674.69
09/22/2020	7009	LUKE MILLER	\$	552.00
09/22/2020	7010	MAGIC SHINE CAR WASH	\$	60.00
09/22/2020	7011	MARCELS PLUMBING, HEATING, COOLING	\$	525.00
09/22/2020	7012	METRO ELEVATOR CO.	\$	106.61

Borough of North Wales CHECK DETAIL REPORT

September 2020

Date	Num	Name		
09/22/2020	7013	NWWA	\$	498.42
09/22/2020	7014	NWWA 30543700-82705	\$	25.90
09/22/2020	7015	PA ONE CALL SYSTEM INC.	\$	7.70
09/22/2020	7016	PA STATE ASSOC OF BOROUGHES	\$	50.00
09/22/2020	7017	PECO 02951-60039 HESS PARK	\$	31.22
09/22/2020	7018	PERSONAL PROTECTION CONSULTANTS, INC.	\$	598.00
09/22/2020	7019	PITNEY BOWES - EQUIP LEASE	\$	159.66
09/22/2020	7020	POINT SERVICE CENTERS INC.	\$	522.97
09/22/2020	7021	REPUBLIC SERVICES #320	\$	119.24
09/22/2020	7022	RUBIN GLICKMAN STEINBERG & GIFFORD	\$	3,000.00
09/22/2020	7023	TRADITIONAL SIGN COMPANY	\$	600.00
09/22/2020	7024	TRANSUNION	\$	50.00
09/22/2020	7025	U. S. BANK EQUIPMENT FINANCE	\$	245.65
09/22/2020	7026	UNUM LIFE INSURANCE COMPANY	\$	615.79
09/22/2020	7027	VICTORY FIRE PROTECTION	\$	1,770.00
09/22/2020	7028	WITMER PUBLIC SAFETY GROUP INC.	\$	21.00
09/22/2020	7029	PECO 67276-01407 STREET LIGHTS	\$	1,376.40
Total 0110010 · GENERAL FUND CHECKING			\$	56,172.77
1910010 · WEINGARTNER PARK CHECKING			\$	-
09/22/2020	1121	PECO 79540-01509 WEINGARTNER	\$	33.97
Total 1910010 · WEINGARTNER PARK CHECKING			\$	33.97
3510010 · LIQUID FUELS CHECKING			\$	-
09/22/2020	1271	CARDMEMBER SERVICE	\$	689.64
09/22/2020	1272	PECO 82667-00208 RED LIGHT	\$	12.43
Total 3510010 · LIQUID FUELS CHECKING			\$	702.07
TOTAL			\$	56,908.81

BOROUGH OF NORTH WALES
 300 SCHOOL STREET
 NORTH WALES, PENNSYLVANIA

REMOTE MEETING: September 8, 2020 7:00 PM, EST

CALL TO ORDER made by President Sando.

ROLL CALL:	Salvatore Amato	Present
	James Cherry	Present
	Sherwin Collins	Present
	Ronald S. Little, Jr.	Present
	Wendy McClure	Present
	Sally Neiderhiser	Present
	Eion O'Neill	Present
	James Sando	Present
	Mark Tarlecki	Present
	Mayor Gregory D'Angelo	Present

Also in attendance were Gregory Gifford, Borough Solicitor, Alan Guzzardo, Assistant Borough Manager and Michael Eves, Chief of Police.

This meeting was held remotely via Zoom due to COVID-19 restrictions.

President Sando led the Pledge of Allegiance.

Public Comment

There was none.

Presentation: Plan Proposal – 501 E. Walnut St.

This presentation was postponed. The applicant notified the Borough earlier in the day that they would like to reschedule. Solicitor Gifford confirmed that he too received a request via email to postpone and reschedule this presentation in October 2020.

Consideration: Approval of Ordinance 816 – General Obligation Note, 2020 Series

Manager Hart reviewed the Ordinance in accordance with the act of June 25, 1941 (P.L.159, No.87), known as the Municipal Borrowing Law, or the act of July 12, 1972 (P.L.781, No.185), known as the Local Government Unit Debt Act. Member Amato asked Manager Hart and Solicitor Gifford to elaborate on the references and plan agreements mentioned in the Ordinance.

Member Amato made a motion to approve Ordinance 816, General Obligation Note, 2020 Series. Member McClure seconded motion. Motion passed 9 yes, 0 no.

Consideration: Approval of Minutes: August 25, 2020

Mayor D'Angelo requested that his comments be amended to state that Alex Sansone had received valuable training while he served the Borough.

Member McClure made a motion to approve the minutes of August 25, 2020 including the amendment suggested by Mayor D'Angelo. Member Neiderhiser seconded motion. Motion passed 9 yes, 0 no.

Consideration: Zoning Hearing Board Appointment, Term Ending 12/31/2023

Member Tarlecki asked if there would now be a vacancy on the Board since Mr. Blackledge was already serving as the alternate member. Manager Hart confirmed there would be a vacancy for the alternate member position and that it would be advertised.

Member O'Neill made a motion to appoint Charles Blackledge to the Zoning Hearing Board, term ending, 12/31/2023. Member Collins seconded motion. Motion passed 9 yes, 0 no.

Old Business/Committee & Board Reports/Zoning Applications

Manager Hart announced that a new tab has been created on the Borough website for the Human Relations Commission and that more information would become available soon. Vice President Cherry asked about the outcomes of Zoning Applications #20-04 and #20-05. Manager Hart informed Council that both applicants were successful and granted relief sought.

Solicitor / Mayor / Council / Chief of Police / Manager

President Sando thanked the Historical Architectural Review Board and Council for approving his recent application for roofing.

Manager Hart announced the following events: Taking the Lead: An Online Event about Marijuana and Youth for Montgomery County Changemakers on September 18, Oktoberfest Takeout Event on September 26, Community Day of Service on October 3 and the North Wales Area Library 5k Run/Walk Event between October 24-31.

President Sando encouraged people to use curbside pickup from local restaurants and participate in the Community Day of Service Event.

Member Neiderhiser made a motion to adjourn. Member McClure seconded the motion. Motion passed 9 yes, 0 no. Meeting adjourned at 7:31 P.M.

Attest: _____

Christine A. Hart
Borough Manager

Every day, Pennsylvania dog wardens are watching out for thousands of furry friends. From returning stray dogs to their owners, to inspecting the kennels where many dogs start their lives and the shelters where many dogs wait patiently for their forever homes, the Bureau of Dog Law is committed to keeping dogs safe.

Contact your legislators about House Bill 1504 and Senate Bill 663. Help Dog Law to continue this vital work.



PA dog wardens work daily for public safety. From investigating the nearly 1,300 dog bites reported in 2019, to charging the owners of dangerous dogs and tracking dangerous dogs' whereabouts for life, the Bureau of Dog Law is committed to serving the people of Pennsylvania. Without proper funding, the safety of citizens may be in jeopardy.

Contact your legislators about House Bill 1504 and Senate Bill 663, your voice matters to ensure these vital tasks can be continued. It's a matter of life and death, or limb...



#DidYouKnow, that in 2008, Pennsylvania dog law underwent a major reform, giving dog wardens the ability to crack down on poor conditions in kennels and ensure that hundreds of thousands of dogs in licensed kennels receive proper care? In addition to conducting these stringent inspections, wardens also work diligently to uncover the many illegal kennels operating in PA. We can't go back!

Contact your legislator to voice your opinion about House Bill 1504 and Senate Bill 663, so that wardens can continue serving those with only a bark.

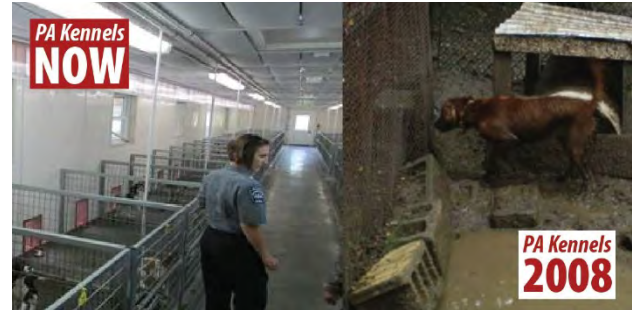

The work our wardens do to protect PA's dogs can't go on without proper funding, contact your legislator to voice your opinion for those who can't about HB 1504 and SB 663.



Can you guess what type of animal did this?

It's a dog bite.

Scary?

Yes.

And, it's even scarier to realize that if the Bureau of Dog Law runs out of funding, dog wardens will no longer be available to investigate these bites and file the necessary charges to help prevent them from happening again. Contact your legislators about House Bill 1604 and Senate Bill 663 to ensure funding is available to protect Pennsylvania from dangerous dogs.



A scared, hungry dog is picked up and returned to its desperate owner. Another stray, injured by a porcupine, is taken for medical care. A malnourished mom and her pups are found wedged under an abandoned home.

Dog wardens work tirelessly for Pennsylvania's canine citizens. Don't let it end. Contact your legislators about House Bill 1504 and Senate Bill 663.



Did you know that PA dog wardens receive humane society police officer training? This training provides them with knowledge about what to look for in kennels and other situations where animal cruelty may be present, allowing them to make a justified cruelty referral to a humane society police officer who can seize dogs and charge for animal cruelty.





LICENSE YOUR DOG.

The dogs of Pennsylvania need your help! The fund that helps protect them will soon run out of money. Thanks to @Senator Judy Schwank and @Representative Eddie Day Pashinski, legislation has been introduced that will #SavePADogLaw and Pennsylvania's furriest residents safe.

Contact your legislators to voice your opinion about these important bills.

#LoveYourDogLicenseYourDog #SavePADogLaw



Last year, the department conducted over 5,800 kennel inspections and issued over 2,700 citations. Help Pennsylvania dog wardens continue cracking down on illegal kennels in the state and protect dogs that start their lives there.

#SavePADogLaw





LICENSE YOUR DOG.

The wellbeing of pups across Pennsylvania is currently at risk. The fund that allows dog wardens to perform this important work is nearly out of money. Don't let this important work stop.

#SavePADogLaw – support Senate Bill 663 and House Bill 1504. Contact your legislator to voice your opinion for those who can't speak for themselves.



Just last year, more than 600 stray dogs were either reunited with their owners or brought to safe shelter to wait for a forever home by PA dog wardens. But the fund that fuels their important work is about to go red.

Support a dog license fee increase in Pennsylvania. It's something that hasn't happened since 1996 (meanwhile everything from a loaf of bread to a gallon of gas has increased by more than 100%!).

It's important for your dog, your neighbors, your community, and every dog in Pennsylvania.

#SavePADogLaw – support Senate Bill 663 and House Bill 1504. Contact your legislator to voice your opinion for those who can't speak for themselves.





LICENSE YOUR DOG.

Did you know that PA dog license fees have not increased since 1996?

In that same time...

- Postage increased by 72%
- A loaf of bread increased by 114%
- A gallon of milk increased by 182%
- A gallon of gas increased by 133%

The Bureau of Dog Law Enforcement will run out of funds to operate in September. Their work protects all Pennsylvanians – both humans and the four-legged and furry.

#SavePADogLaw – support Senate Bill 663 and House Bill 1504. Contact your legislator to voice your opinion for those who can't speak for themselves.





North Wales Borough Police Department
300 School Street, North Wales, Pa. 19454

Phone: 215-699-9279 Fax: 215-699-3765
E-Mail: NWPD@northwalesborough.org

Memo To: Christine Hart, Borough Manager
From: Michael Eves, Chief of Police
RE: Police Budget Transfer Requests
Date: September 17, 2020

Christine,

Due to some recent manpower issues and the resulting overtime, may I request the following budget line transfers to get us through the year with staffing and to hire an additional Part-Time Police Officer to reduce the need for police overtime:

AMOUNT	FROM	TO
\$2,000.00	0141029: Ammo and Related	0141028: Uniforms, Police
\$5,000.00	0141033: Gasoline, Police	0141018 Overtime Wages, Police
\$3000.00	0141024: Operating Exp. Police	0141018: Overtime Wages, Police
\$3000.00	0141050: Training, Police	0141018: Overtime Wages, Police

Respectfully,

Michael E. Eves
Chief of Police
North Wales Borough Police Department
(215) 699-9270 ext. 104
meves@northwalesborough.org

Borough of North Wales
Profit & Loss Budget vs. Actual
 January 1 through September 15, 2020

	Jan 1 - Sep 15, 20	Budget	\$ Over Budget	% of Budget
Ordinary Income/Expense				
Income				
0133110 · COURT	3,183.48	9,000.00	-5,816.52	35.4%
0133111 · VEHICLE CODE VIOLATIONS	2,572.44	7,000.00	-4,427.56	36.7%
0133112 · CODE VIOLATIONS	449.69	500.00	-50.31	89.9%
0136211 · ACCIDENT REPORT FEES	345.00	700.00	-355.00	49.3%
0138330 · POLICE SERVICES	434.00	700.00	-266.00	62.0%
Total Income	6,984.61	17,900.00	-10,915.39	39.0%
Gross Profit	6,984.61	17,900.00	-10,915.39	39.0%
Expense				
0141010 · WAGES - CHIEF	74,764.80	108,000.00	-33,235.20	69.2%
0141012 · WAGES - POLICE CLERICAL	13,808.41	26,910.00	-13,101.59	51.3%
0141013 · WAGES - CROSSING GUARDS	7,062.00	7,500.00	-438.00	94.2%
0141014 · WAGES - FULL TIME OFFICERS	202,646.26	295,150.87	-92,504.61	68.7%
0141015 · WAGES - P/T OFFICERS	53,082.01	75,000.00	-21,917.99	70.8%
0141016 · LONGEVITY / EDUCATION INCENTIVE	3,625.00	6,525.00	-2,900.00	55.6%
0141017 · HOLIDAY PAY	0.00	5,700.00	-5,700.00	0.0%
0141018 · OVERTIME WAGES, POLICE	28,818.97	30,000.00	-1,181.03	96.1%
0141021 · OFFICE SUPPLIES, POLICE	478.10	1,500.00	-1,021.90	31.9%
0141024 · OPERATING EXP, POLICE	1,368.73	5,500.00	-4,131.27	24.9%
0141025 · MAINT/REPAIRS	105.00	2,000.00	-1,895.00	5.3%
0141026 · MINOR EQUIPMENT, POLICE	5,027.67	7,000.00	-1,972.33	71.8%
0141028 · UNIFORMS, POLICE	7,457.98	7,500.00	-42.02	99.4%
0141029 · AMMO & RELATED SUPPLIES	420.52	3,250.00	-2,829.48	12.9%
0141031 · PROFESSIONAL SERVICES, POLICE	2,696.00	8,000.00	-5,304.00	33.7%
0141032 · COMMUNICATIONS - PHONE/RADIO	1,756.11	3,500.00	-1,743.89	50.2%
0141033 · GASOLINE, POLICE	5,429.40	15,000.00	-9,570.60	36.2%
0141034 · PRINTING, POLICE	398.22	1,000.00	-601.78	39.8%
0141037 · VEHICLE MAINT/REPAIRS	4,731.70	10,000.00	-5,268.30	47.3%
0141042 · DUES/SUBSCRIPTIONS, POLICE	225.00	750.00	-525.00	30.0%
0141044 · UNIFORM MAINTENANCE, POLICE	2,054.00	2,000.00	54.00	102.7%
0141045 · CONTRACTED SRVCS	4,996.91	7,500.00	-2,503.09	66.6%
0141046 · TRAINING, POLICE	2,192.00	7,500.00	-5,308.00	29.2%
0141050 · EMERGENCY MGMT/C100 UNIT	3,000.00	3,000.00	0.00	100.0%
Total Expense	426,144.79	639,785.87	-213,641.08	66.6%
Net Ordinary Income	-419,160.18	-621,885.87	202,725.69	67.4%
Net Income	-419,160.18	-621,885.87	202,725.69	67.4%



TAKE OUT MENU

Saturday, September 26th

3 pm to 6 pm

- OPTION 1: Traditional Oktoberfest Fare\$15**
2 brats, 2 buns, potato salad, pretzel, sauerkraut & apple kuchen.
- OPTION 2: Children's Sweet Delight Oktoberfest Fare\$15**
2 hot dogs, 2 buns, pretzel, potato chips, & German chocolate.
- OPTION 3: Family Munich Oktoberfest Wurstplatte - Feeds Five\$55**
2 Nuremberger, 2 knackwurst, 2 Munich bratwurst, 2 brats,
2 smoked sausages, with 5 buns, potato salad, pierogis,
sauerkraut & apple kuchen.
- OPTION 4: Small Oktoberfest Wurstplatte - Feeds Two\$30**
1 nurembeger, 1 knackwurst, 1 Munich bratwurst, 1 brat,
with 2 buns, potato salad, pierogis, sauerkraut & applekuchen.
- OPTION 5: Schnitzelplatte\$35**
Including: 3 wiener schnitzel (breaded veal), potato salad,
coleslaw & applekuchen.

PRE-ORDER ONLY: Orders **MUST** be received by Sat., Sept. 19th.

See our website for order instructions: www.stpetersnorthwales.org

PICKUP: Please call **267-254-8674** upon arrival to the church parking lot.

You're invited to participate in the 7th annual

Community Day of Service

Saturday, October 3, 2020

8:30 am – 12:00 pm

We Need Your Help to Help Others!

Join friends and neighbors on October 3rd: We tackle and complete small outdoor projects working in a team environment to help those in need (homebound elderly, those that are ill or facing financial difficulty, community-based projects.) This year, to provide a safe environment, all participants will wear face masks and practice social distancing.

Help Us Identify Projects

Do you have a neighbor, family member, or friend in the North Wales/Gwynedd area who could use a little extra help on a yard cleanup/landscape or outdoor minor home repair project?

To volunteer your time or resources or to suggest a project, please call 215-767-9694 or send an email to NWDayofService@gmail.com

REGISTRATION FORM

**Please complete one form per entrant*
Register at www.northwaleslibrary.org or
mail in completed form.

Name: _____

Address: _____

City: _____

State: _____ Zip Code: _____

Phone: _____

Email: _____

School: _____

Men Women Age: _____

Registration Fees (Runner/Walker)

- \$20 No Shirt
- \$25 With Shirt pick up at NWAL
- \$30 Mail Shirt to You

T-Shirt Size (circle your preference)

Adult: S M L
Youth: M

Add Donation: _____

Amount Enclosed: _____

Checks payable to
North Wales Area Library
233 S. Swartley St.
North Wales, PA 19454



North Wales Area Library
233 S, Swartley St.
North Wales, PA 19454

Questions?
Call (215) 699-5410
610.613.0695 (cell)
or email
jmarzewski@northwaleslibrary.org

Mon - Thu 11am - 7pm
Closed Friday Saturday
Noon-4 Closed Sunday.



1ST ANNUAL

**LITERARY
CHARACTER**

**5K/RUN
& WALK**

OCT 24 - 31, 2020

**families
welcome!**

**Prizes
for
costumes!**



**A VIRTUAL EVENT
THROUGH PRETZEL CITY SPORTS**

HERE'S HOW OUR VIRTUAL 5K WORKS

1 Register individually at www.northwaleslibrary.org

2 Run a 5K or walk one mile anytime between Oct. 24 and 6:00pm Oct. 31

3 Set a course in your neighborhood, in a park, or on a track.

4 Send your results in our virtual 5K race to jmarzewski@northwaleslibrary.org

SEND US YOUR RACE PICTURES!

They will be posted on the Library website, and Facebook!
www.northwaleslibrary.org

Costume winners will be announced November 1

race details

- **Registration Fees**
 - \$20 No Shirt
 - \$25 With Shirt
 - \$30 Mail Shirt to You

- **Deadline to register for shirt is Oct 15.**
Can still register to participate through October 30, however, shirt is not guaranteed.

- **T-Shirt pick up Oct. 23 - Oct. 30 at NWAL**

REGISTER TODAY!

Registration available at www.northwaleslibrary.org
or mail to
North Wales Area Library 233
S. Swartley St.
North Wales, PA 19454



● **waiver**
On behalf of myself, my heirs, executors, successors and assigns to the fullest extent of the law, I hereby waive and release all rights and claims for damages which I may have against the North Wales Area Library, its Administration and its employees, all sponsors, leaders, and volunteers, or anyone else connected with the event and agree to indemnify and hold harmless from any and all claims, suits, judgments, and demands whatsoever, including without limitation, costs, litigation expenses, counsel fees and liabilities with respect to injury, illness or death which I may suffer as a result of taking part in this event. I have been warned that I must be in good health to participate in this event.

Also, none of the above is responsible for the loss of personal items or any other form of aggravation in connection with this event. I grant my permission to use my name or any audio or visual for any lawful purpose.

I have read and understand the above waiver.

Signature: _____
(signature of Parent/Guardian if under 18)

Date: _____



Borough Boards & Commissions Vacancies

- Historical Architectural Review Board – Term Expires: 12/31/2023
Must be a licensed real estate broker.
- Parks & Recreation Board – Term Expires: 12/31/2020
- Parks & Recreation Board – Term Expires: 12/31/2022
- Parks & Recreation Board – Term Expires: 12/31/2023
- Zoning Hearing Board (Alternate) – Term Expires: 12/31/2022

Please submit a letter of interest for any one or more of the above listed openings, addressed to the North Wales Borough Council in care of the Borough Manager. Letters can be submitted electronically to chart@northwalesborough.org.